

Item No.	Description	Qty
1	Main Valve Bermad 400Y ANS#150	1
2	Pressure Sustaining Pilot Valve #2PB	1
3	Restriction Orifice Insert	1
4	Y Strainer	1

Optional Items		
I	Visual Position Indicator	1
S	Limit Switch Assembly	1
C	Tamper proof Cup	1

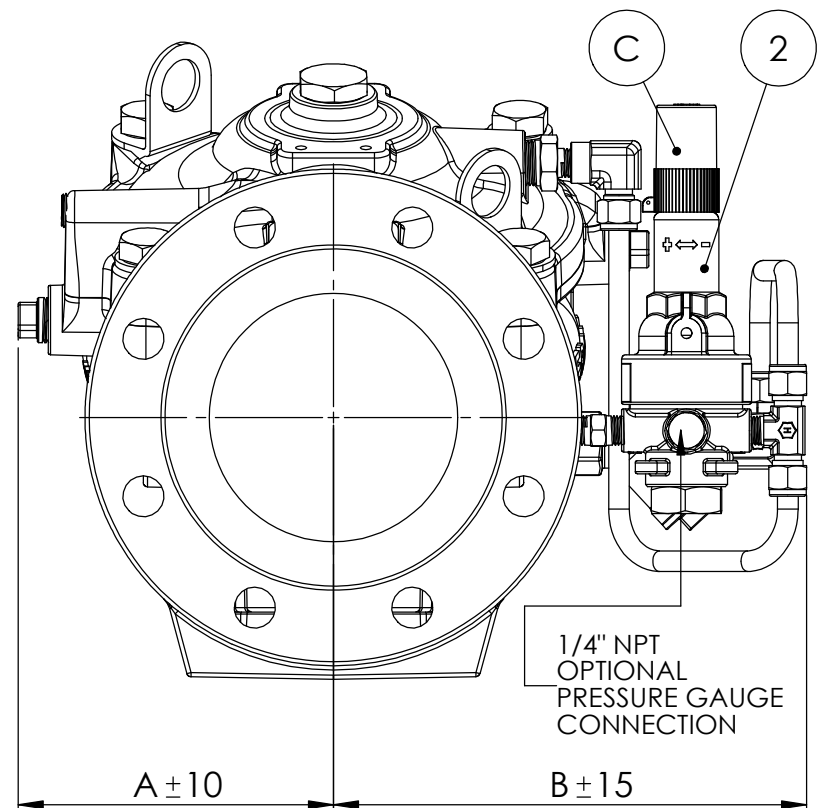
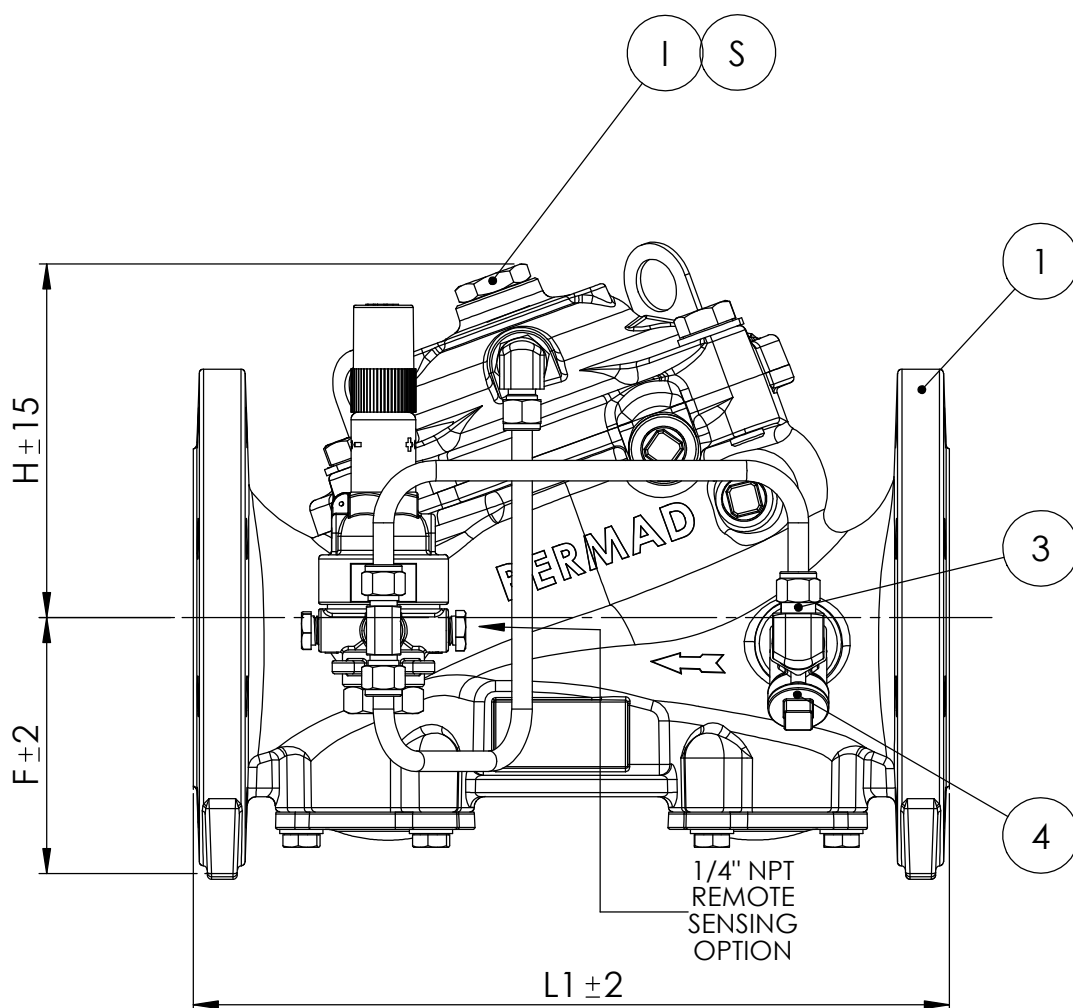

Valve Size	1½"	2"	3"	4"	6"
DN	40	50	80	100	150
H	120	125	160	185	248
F	51	56	82	95	116
L1	230	230	310	350	480
A	78	78	125	146	201
B	165	186	200	214	244
Weight(Kg)	11.9	13.3	28	38	81.3

NOTES :

1). ADD 45mm WHEN USING VISUAL POSITION INDICATOR, AND 120mm FOR ENCLOSED LIMIT SWITCH.

* ALL DIMENTIONS ARE IN METRIC mm UNLESS MENTIONED OTHERWISE
 * PROVIDE AMPLE CLEARANCE FOR FUTURE MAINTENANCE.

THIS DOCUMENT IS BERMAD'S PROPERTY AND CANNOT BE USED BY OTHERS FOR ANY PURPOSE WITHOUT PRIOR WRITTEN CONSENT.

CATALOG No.	PC7-FP-4-42T-H-C-16-ER-NN		
	Project Name:	Material:	Finish:
	Doc. Code:	DESCRIPTION: Pressure Reducing Valve	
DESIGN	Alex Dehtar	05.05.2019	
DRAWN	Alexander Bezrebriy	05.05.2019	File name: PC7-FP-4-42T-H-C-16-ER-NN
APPROVED	Alex Dehtar	07.05.2019	DWG No. 016465 WEIGHT [Kg]: Table
			SCALE: 1:4
			A3
			SHEET 1 OF 1 REV. 0

