

Item No.	Description	Qty
1	Main Valve BERMAD 400Y Series	1
2	Pressure Reducing Pilot Valve #2PB/PBL	1
3	Restriction Orifice Insert	1
4	Y Strainer	1
5	Check Valve	2

Optional Items		
I	Valve Visual Position Indicator	1
S	Enclosed Limit Switch Assembly	1
Y	Back Flow Y Strainer, for Dirty Water	1
C	Tamper Proof Cup	1

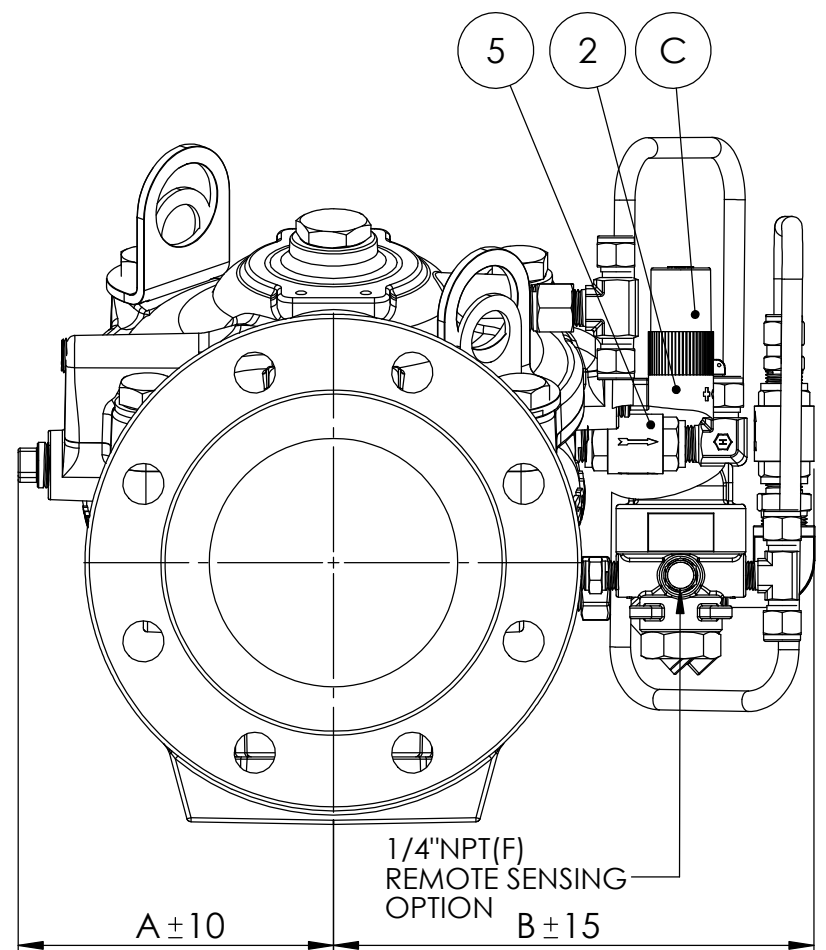
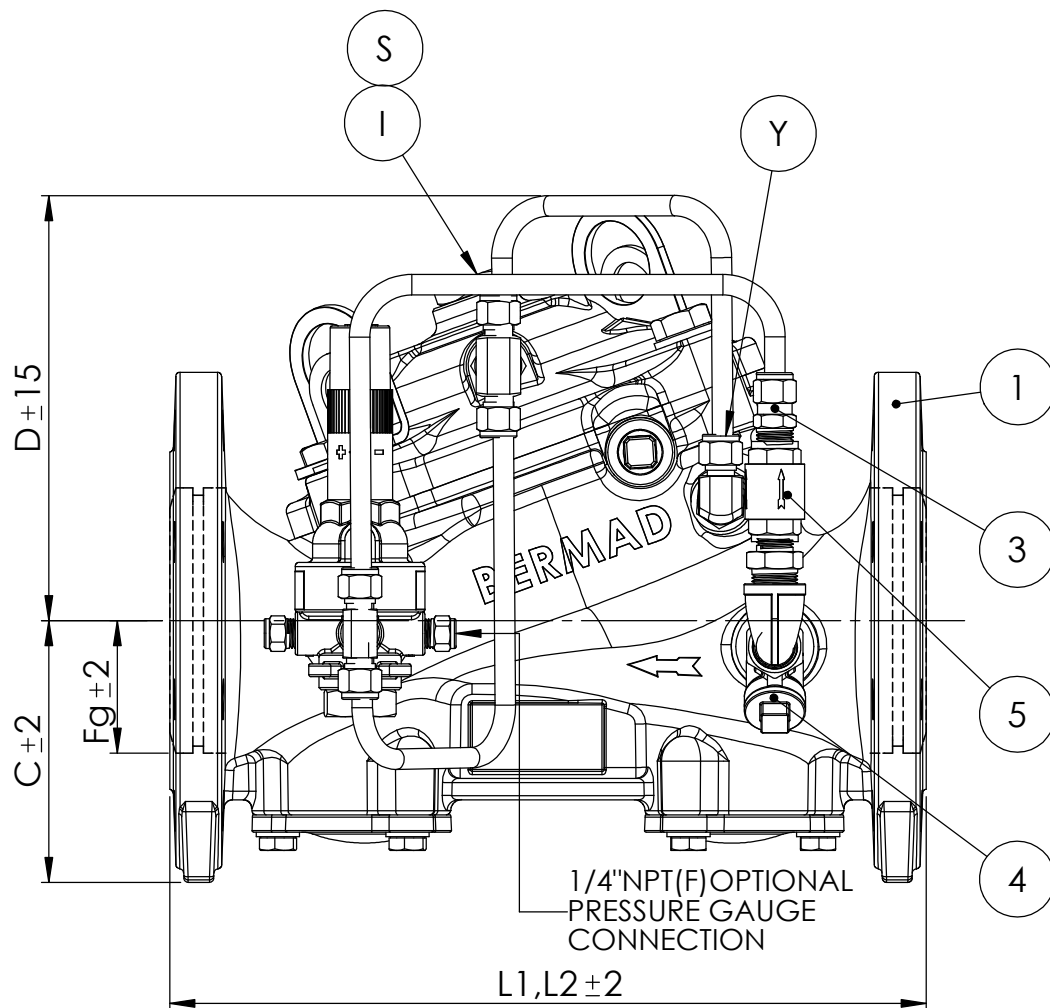

Valve Size	1½"	2"	3"	4"	6"	8"	10"
DN	40	50	80	100	150	200	250
D (3)	150	145	183	193	262	325	325
C	65	77	103	115	140	172	204
Fg (Grooved)	23	38	44.5	57.2	84.2	110	-
L1 (1)	230	230	310	350	480	600	730
L2 (2)	230	235	325	367	505.5	626	730
A	78	76	139	147	200	172	204
B	165	175	223	254	268	490	490
Weight #150	9.4	10.8	27.5 Kg	37.5 Kg	81 Kg	149 Kg	178 Kg
Weight #300	11.8	12.7	32.2 Kg	44.9 Kg	100.8 Kg	166 Kg	212 Kg
Grooved Weight	7.3	7.1	20.5 KG	25.9 Kg	71.7 Kg	77.6 Kg	83.8 Kg

TABLE NOTES :

- 1) L1 DIMENSIONS ARE FOR ANSI#150RF/ISO PN16 FLANGED VALVES.
- 2) L2 DIMENSIONS ARE FOR GROOVED (2"-8") AND ANSI#300RF/ISO PN25 VALVES.
- 3) ADD 45mm WHEN USING VISUAL POSITION INDICATOR, AND 120mm FOR ENCLOSED LIMIT SWITCH.

* ALL DIMENSIONS ARE IN METRIC mm UNLESS MENTIONED OTHERWISE

NOTES:

- 1). PROVIDE AMPLE CLEARANCE FOR FUTURE MAINTENANCE.
- 2). ALL DIMENSIONS ARE APPROXIMATED, E&OE.

THIS DOCUMENT IS BERMAD'S PROPERTY AND CANNOT BE USED BY OTHERS FOR ANY PURPOSE WITHOUT PRIOR WRITTEN CONSENT.

CATALOG No.	PC8-FP-4-42T-20-H-C-16-ER-NN		
	Project Name: Torrent-2015 Drawings		Material: - Finish: -
	Doc. Code:		DESCRIPTION: Pressure Reducing Valve
DESIGN	Alex Dehtar	05.05.2019	
DRAWN	Alexander Bezrebriy	05.05.2019	
APPROVED	Lior Weinstain	07.05.2019	
File name: PC8-FP-4-42T-20-H-C-16-ER-NN		SCALE:	A3
DWG No. 022312		WEIGHT [Kg]:	SHEET 1 OF 1 REV. 00